

DHI-ARD512-W2(868)

Dahua Wireless Glass Break Detector



- Detects when the glass is broken, triggering alarms for different types of glass such as tempered, double-glazed, laminated, wired, plate and float glass.
- Detects high and low frequency sounds at the same time, and uses algorithms to reduce the occurrence of false alarms.
- Two-channel alarm input.
- Cloud update and automatic recovery from update failure.
- The two-way wireless encrypted communication mechanism improves the security and stability of communication.
- With the wireless frequency hopping mechanism, the device automatically hops to other available frequency bands when the original frequency band is being interfered with by other wireless radios, to ensure communication remains stable.

System Overview

The Wireless Glass Break Detector recognizes when different types of glass are breaking, triggering alarms in real time. With its advanced technology, it picks up the low-frequency and high-frequency that glass breaks at, reducing the occurrence of false alarms caused by noise interference from the environment. It also comes with 2 external ports that can connect to third-party wired detectors. When placed in a home or building, it helps protect families and work places from intrusions.

Technical Specification

Port	
Alarm Input	2 (NO/NC)
Microphone	Highly-sensitive omnidirectional microphone
Function	
Button	1 × power button
Remote Update	Cloud update
Low Battery Detection	Yes
Tamper	Yes
Technical	
Detection Range	Max. 9 m (29.53 ft)
Specifications of Glass to be Detected	Glass type: Tempered, double-glazed, laminated, wired, plate and float Glass thickness: 2.4 mm–6.4 mm (0.09"–0.25") Glass size: 0.3 m × 0.3 m to 3 m × 3 m (0.98 ft × 0.98 ft to 9.84 ft × 9.84 ft)
Test Mode	Yes
LED Indicator	1 × green alarm indicator
Scenario	Indoor
Operating Current	45 uA
Alarm Current	50 mA

Wireless

Carrier Frequency	868.0 MHz–868.6 MHz
Communication Mechanism	Two-way
Communication Distance	1,600 m (5,249.34 ft)
Encryption Mode	AES128
Frequency Hopping	Yes

General

Power Supply	1 × CR123A battery
Battery Model	CR123A
Battery Life	3 years (The external input type is NO) 1 year (Both external sensors are enabled, and the input type is NC)
Power Consumption	Max. 150 mW
Operating Temperature	–10 °C to +55 °C (+14 °F to +131 °F) (indoor)
Operating Humidity	10%–90% (RH)
Product Dimensions	107.8 mm × 34.5 mm × 24.8 mm (4.24" × 1.36" × 0.98")
Net Weight	45 g (0.10 lb)
Gross Weight	130 g (0.29 lb)
Installation	Surface mount
Casing Material	PC and ABS
Appearance Color	White
Certifications	CE
Anti-corrosion Level	Basic Protection
Packaging Dimensions	95 mm × 43 mm × 139 mm (3.74" × 1.69" × 5.47")

Installation

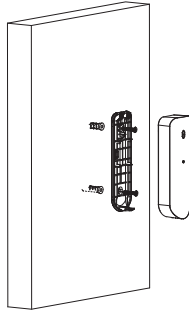

Dimensions (mm/inch)

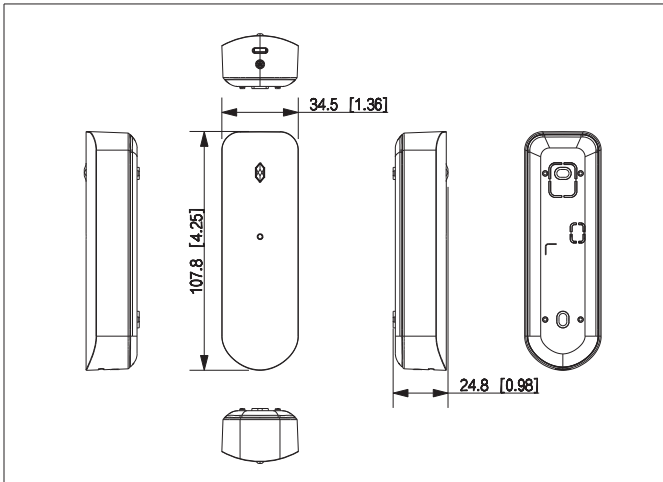

Application

